



# CPD15/20 CPD30/35L1 (S)

1.5/2.0/3.0/3.5T Elektro-Gegengewichtsstapler

- Erster Gegengewichtsstapler der Welt, der um die Batterie gebaut ist
- Hohe Effizienz bei hoher Leistung
- Die Li-Ion Batterie verkürzt die Ladezeit auf 2,5 Stunden
- Hoher Komfort für den Betrieb mit größeren Fahrerplatz

**LI-ION**  
TECHNOLOGY

**EP EQUIPMENT CO.,LTD**  
[www.ep-ep.com](http://www.ep-ep.com)



# 1.5/2.0T Elektro-Gegengewichtsstapler

## CPD15/20L1

Kennzeichen	1.1	Hersteller (Kurzbezeichnung)			EP	EP
	1.2	Typzeichen des Herstellers			CPD15L1	CPD20L1
	1.3	Antrieb			Electric	Electric
	1.4	Bedienung			Seated	Seated
	1.5	Nenntragfähigkeit/Last	Q	kg	1500	2000
	1.6	Lastschwerpunktabstand	c	mm	500	500
	1.8	Lastabstand	x	mm	405	405
	1.9	Radstand	y	mm	1470	1470
	Gewichte	2.1	Eigengewicht		kg	2640
2.2		Achslast mit Last vorn/hinten		kg	3615/525	4380/570
2.3		Achslast ohne Last vorn/hinten		kg	1190/1450	1155/1795
Räder/Fahrwerk	3.1	Bereifung			Solid Rubber	Solid Rubber
	3.2	Reifengröße, vorn			18x7-8	200/50-10
	3.3	Reifengröße, hinten			5.00-8	5.00-8
	3.5	Räder, Anzahl vorn/hinten (× = angetrieben)		mm	2x/ 2	2x/ 2
	3.6	Spurweite, vorn	b10	mm	910	910
	3.7	Spurweite, hinten	b11	mm	920	920
	Dimensions	4.1	Neigung Hubgerüst/Gabelträger vor/zurück	α/β	°	6/11
4.2		Höhe Hubgerüst eingefahren	h1	mm	1990	1990
4.3		Freihub	h2	mm	105	105
4.4		Hub	h3	mm	3000	3000
4.5		Höhe Hubgerüst ausgefahren	h4	mm	4028	4028
4.7		Höhe Schutzdach (Kabine)	h6	mm	2080	2080
4.8		Sitzhöhe bezogen auf SIP/Standhöhe	h7	mm	1050	1050
4.12		Kupplungshöhe	h10	mm	360	360
4.19		Gesamtlänge	l1	mm	3270	3270
4.20		Länge einschließlich Gabelrücken	l2	mm	2200	2200
4.21		Gesamtbreite	b1/b2	mm	1080	1080
4.22		Gabelzinkenmaße DIN ISO 2331	s/e/l	mm	40×100×1070	40×122×1070
4.23		Gabelträger ISO 2328, Klasse/Typ A, B			2A	2A
4.24		Gabelträgerbreite	b3	mm	1040	1040
4.31		Bodenfreiheit mit Last unter Hubgerüst	m1	mm	110	110
4.32		Bodenfreiheit Mitte Radstand	m2	mm	105	105
4.34.1		Arbeitsgangbreite bei Palette 1000 × 1200 quer	Ast	mm	3685	3685
4.34.2		Arbeitsgangbreite bei Palette 800 × 1200 quer	Ast	mm	3885	3885
4.35		Wenderadius	Wa	mm	2080	2080
Leistungsdaten		5.1	Fahrgeschwindigkeit mit/ohne Last		km/h	10.5/14
	5.2	Hubgeschwindigkeit mit/ohne Last		m/s	0.3/0.42	0.28/0.42
	5.3	Senkgeschwindigkeit mit/ohne Last		m/s	0.42/0.45	0.43/ 0.45
	5.5	Zugkraft mit/ohne Last		N	—	—
	5.6	Max. Zugkraft mit/ohne Last		N	—	10000
	5.8	Max. Steigfähigkeit mit/ohne Last		%	10.5/14	10.5/14
	5.10	Betriebsbremse			Electromagnetic	Electromagnetic
	5.11	Feststellbremse			Electromagnetic	Electromagnetic
E-Motor	6.1	Fahrmotor, Leistung S2 60 min		kW	6	6
	6.2	Hubmotor, Leistung bei S3 15 %		kW	7.5	7.5
	6.4	Batteriespannung/Nennkapazität K5		V/Ah	48/360	48/360
	6.5	Batteriegewicht		kg	260	260
	Sonstiges	8.1	Ausführung des Fahrtriebs			AC
10.5		Ausführung Lenkung			Hydraulic	Hydraulic
10.7		Schalldruckpegel L pAZ (Fahrerplatz)		dB(A)	70	70

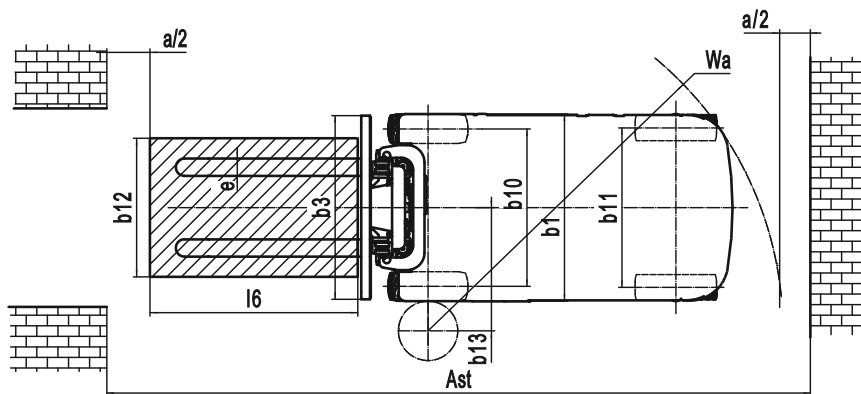
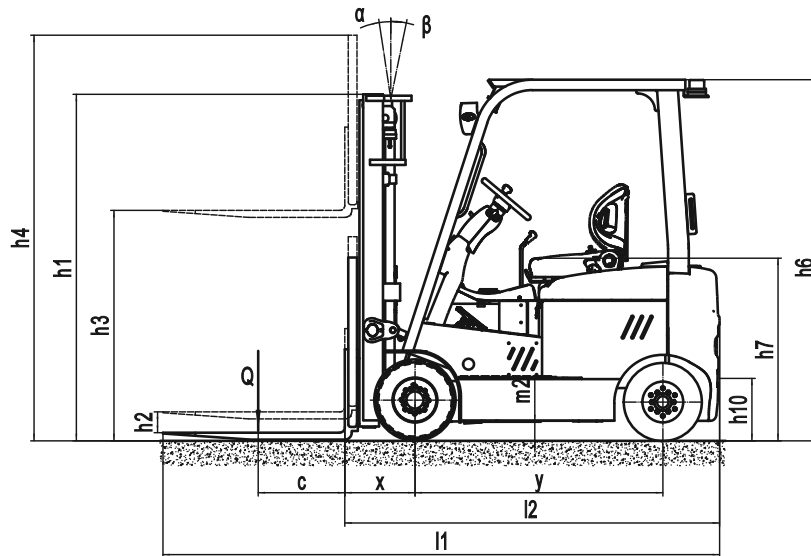

## Die Option Hubgerät

Type	Model	Max. Gabel-höhe H3 mm	Gesamthöhe			Freihub		Front Overhang X mm	Tilt Bereich		Tragkraft	
			Gesenkt h1 mm	ausgefahren		Ohne LSG mm	Ohne LSG h2 mm		FWD α Deg	BWD β Deg	LSP 500mm	
				Ohne LSG mm	Ohne LSG h4 mm						Einzel- bereifung	1.5t kg
Mât duplex ZT	2W200	2000	1490	2485	3028	105	105	405	6	11	1500	2000
	2W250	2500	1740	2985	3528	105	105	405	6	11	1500	2000
	2W270	2700	1840	3185	3728	105	105	405	6	11	1500	2000
	2W300	3000	1990	3485	4028	105	105	405	6	11	1500	2000
	2W330	3300	2140	3785	4328	105	105	405	6	11	1500	1960
	2W350	3500	2240	3985	4528	105	105	405	6	11	1500	1920
	2W360	3600	2290	4085	4628	105	105	405	6	11	1500	1900
	2W400	4000	2540	4485	5028	105	105	405	6	11	1400	1850
Mât double Z	2F250	2500	1773	2985	3528	1288	745	405	6	11	1500	2000
	2F270	2700	1873	3185	3728	1388	845	405	6	11	1500	2000
	2F300	3000	2023	3485	4028	1538	995	405	6	11	1500	2000
	2F330	3300	2173	3785	4328	1688	1145	405	6	11	1500	1960
	2F360	3600	2323	4085	4628	1838	1295	405	6	11	1500	1900
	2F400	4000	2523	4485	5028	2038	1495	405	6	11	1400	1850
Mât triple DZ	3F435	4350	1995	4844	5378	1501	967	415	6	6	1300	1650
	3F450	4500	2045	4994	5528	1551	1017	415	6	6	1250	1550
	3F480	4800	2145	5294	5828	1651	1117	415	6	6	1100	1400
	3F500	5000	2210	5494	6028	1716	1182	415	3	6	950	1250

## Relevante Traglasten mit Lastschwerpunkt Grafik

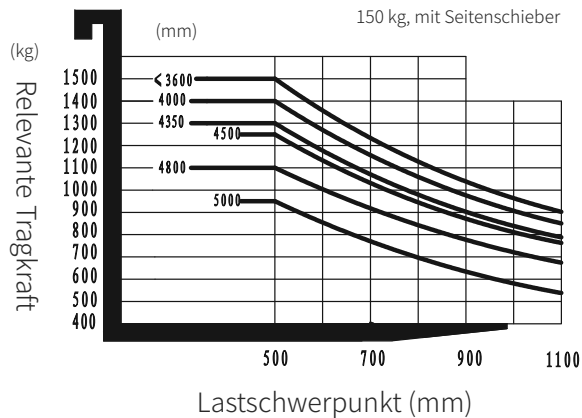

## Relevante Traglasten mit Lastschwerpunkt Grafik

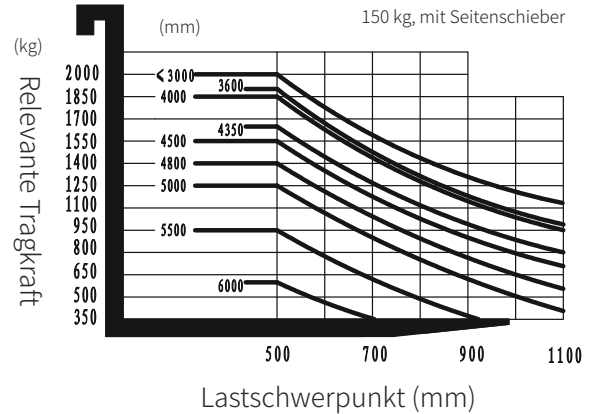

## Optionen

No.	Optionale Elemente	CPD15L1	CPD20L1
1.1	Gabellänge	○100*40*920○100*40*1070○100*40*1150 ○100*40*1220○100*40*1370○100*40*1520 ○100*40*1800	○122*40*920○122*40*1070○122*40*1150 ○122*40*1220○122*40*1370○122*40*1500 ○122*40*1600○122*40*1700○122*40*1820
1.4	Breite des Gabelträgers	●1040mm○Yes and can be customized	●1040mm○Yes and can be customized
1.5	Höhe der Rückenlehne	●1010mm○Yes and can be customized	●1010mm○Yes and can be customized
2.5	Material Vorderrad	●Solid○Non-marking solid	●Solid○Non-marking solid
2.6	Material Hinterrad	●Solid○Non-marking solid	●Solid○Non-marking solid
2.7	Batteriekapazität	○48V280AH○48V405AH	○48V280AH○48V405AH
2.8	Ladegerät	○48V100A○48V150A	○48V100A○48V150A
2.9	Batterieanzeige	●With time	●With time
2.10	Fahrersitz	●Premium○Suspension○Suspension+Seatbelt logic switch ○Suspension seat with armrest (KL01)	●Premium○Suspension○Suspension+Seatbelt logic switch ○Suspension seat with armrest (KL01)
2.11	Anbaugeräte	●No○Built-in sideshifter ○External shifter○Fork positioner	●No○Built-in sideshifter ○External shifter○Fork positioner
2.13	Traktionsbolzen	●Yes	●Yes
2.14	antistatische Kette	●Yes	●Yes
3.1	Klappbare Gabel	●No○Yes and can be customized	●No○Yes and can be customized
3.5	Scheinwerfer vorn	●LED	●LED
3.6	Scheinwerfer hinten	●No○LED	●No○LED
3.7	Warnlicht	●Yes	●Yes
3.8	Lenkradlampe	●Yes	●Yes
3.9	Blaue Signalleuchte	●No○2 front○1 rear○2 front + 1 rear	●No○2 front○1 rear○2 front + 1 rear
3.10	Bereichs-Warnleuchte	●No○Red, 1 left + 1 right	●No○Red, 1 left + 1 right
3.11	Rückspiegel	●1 rearview mirror○Add one on both sides	●1 rearview mirror○Add one on both sides
3.12	Hupe	●Yes	●Yes
3.17	OPS system	●No○Yes and can be customized	●No○Yes and can be customized
3.19	USB-Schnittstelle	●Yes	●Yes
3.23	Telematics	●No○Yes and can be customized	●No○Yes and can be customized
4.1	Seitlicher Batteriewechsel	●No○Yes and can be customized	●No○Yes and can be customized
4.3	Kabine	●No○Basic semi-enclosed cabin ○Upgrade semi-enclosed cabin○Full cabin	●No○Basic semi-enclosed cabin ○Upgrade semi-enclosed cabin○Full cabin
4.9	Heizgerät	●No○Yes and can be customized	●No○Yes and can be customized

Note: ●Standard ○ Optional - Inconformity

# 3.0/3.5T Elektro-Gegengewichtsstapler CPD30/35L1S

Kennzeichen	1.1	Hersteller (Kurzbezeichnung)			EP	EP
	1.2	Typzeichen des Herstellers			CPD30L1S	CPD35L1S
	1.3	Antrieb			Electric	Electric
	1.4	Bedienung			Seated	Seated
	1.5	Nenntragfähigkeit/Last	Q	kg	3000	3500
	1.6	Lastschwerpunktabstand	c	mm	500	500
	1.8	Lastabstand	x	mm	500	500
	1.9	Radstand	y	mm	1698	1698
	Gewichte	2.1	Eigengewicht		kg	4830
2.2		Achslast mit Last vorn/hinten		kg	6840/990	7640/1010
2.3		Achslast ohne Last vorn/hinten		kg	2065/2765	2075/3075
Räder/Fahrwerk	3.1	Bereifung			Solidrubber	Solidrubber
	3.2	Reifengröße, vorn			23X10-12	23X10-12
	3.3	Reifengröße, hinten			200/50-10	200/50-10
	3.5	Räder, Anzahl vorn/hinten (* = angetrieben)		mm	2x/2	2x/2
	3.6	Spurweite, vorn	b10	mm	1085	1085
	3.7	Spurweite, hinten	b11	mm	1020	1020
	Dimensions	4.1	Neigung Hubgerüst/Gabelträger vor/zurück	a/β	°	5/9
4.2		Höhe Hubgerüst eingefahren	h1	mm	2060	2060
4.3		Freihub	h2	mm	140	140
4.4		Hub	h3	mm	3000	3000
4.5		Höhe Hubgerüst ausgefahren	h4	mm	4095	4095
4.7		Höhe Schutzdach (Kabine)	h6	mm	2210	2210
4.8		Sitzhöhe bezogen auf SIP/Standhöhe	h7	mm	1120	1120
4.12		Kupplungshöhe	h10	mm	380	380
4.19		Gesamtlänge	l1	mm	3640	3660
4.20		Länge einschließlich Gabelrücken	l2	mm	2570	2590
4.21		Gesamtbreite	b1/b2	mm	1298	1356
4.22		Gabelzinkenmaße DIN ISO 2331	s/e/l	mm	45×125×1070	50×125×1070
4.23		Gabelträger ISO 2328, Klasse/Typ A, B			3A	3A
4.24		Gabelträgerbreite	b3	mm	1228	1228
4.31		Bodenfreiheit mit Last unter Hubgerüst	m1	mm	130	130
4.32		Bodenfreiheit Mitte Radstand	m2	mm	125	125
4.34.1		Arbeitsgangbreite bei Palette 1000 × 1200 quer	Ast	mm	4090	4100
4.34.2		Arbeitsgangbreite bei Palette 800 × 1200 quer	Ast	mm	4290	4300
4.35		Wenderadius	Wa	mm	2390	2400
Leistungsdaten	5.1	Fahrgeschwindigkeit mit/ohne Last		km/h	15/16	15/16
	5.2	Hubgeschwindigkeit mit/ohne Last		m/s	0.4/0.45	0.4/0.45
	5.3	Senkgeschwindigkeit mit/ohne Last		m/s	0.44/0.48	0.44/0.48
	5.5	Zugkraft mit/ohne Last		N	—	—
	5.6	Max. Zugkraft mit/ohne Last		N	—	17800
	5.8	Max. Steigfähigkeit mit/ohne Last		%	16/20	16/20
	5.10	Betriebsbremse			Hydraulic	Hydraulic
	5.11	Feststellbremse			Mechanical	Mechanical
E-Motor	6.1	Fahrmotor, Leistung S2 60 min		kW	16.6	16.6
	6.2	Hubmotor, Leistung bei S3 15 %		kW	24	24
	6.4	Batteriespannung/Nennkapazität K5		V/Ah	80/560	80/560
	6.5	Batteriegewicht		kg	420	420
	Sonstiges	8.1	Ausführung des Fahrtriebs			AC
10.5		Ausführung Lenkung			Hydraulic	Hydraulic
10.7		Schalldruckpegel L pAZ (Fahrerplatz)		dB(A)	70	70

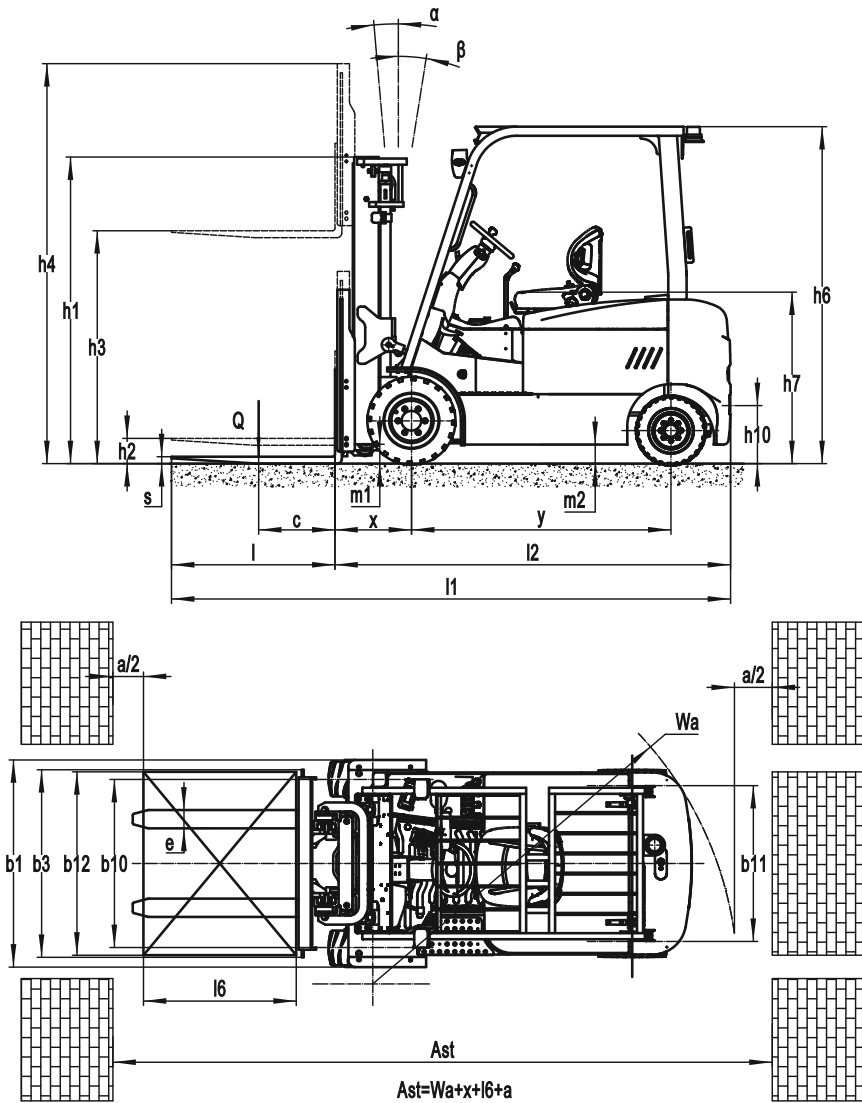

## Die Option Hubgerät

Type	Model	Max. Gabel-höhe H3	Gesamthöhe				Freihub		Front Overhang X		Tilt Bereich		Tragkraft	
			Gesenkt h1	ausgefahren		Ohne LSG h1	Ohne LSG h2	FWD $\alpha$			BWD $\beta$	LSP 500mm		
				Ohne LSG	Ohne LSG h4				3t	3.5t				
												mm	mm	mm
Duplex ZT	2W200	2000	1560	2705	3095	140	140	500	500	5	9	3000	3500	
	2W250	2500	1810	3205	3595	140	140	500	500	5	9	3000	3500	
	2W270	2700	1910	3405	3795	140	140	500	500	5	9	3000	3500	
	2W300	3000	2060	3705	4095	140	140	500	500	5	9	3000	3500	
	2W330	3300	2210	4005	4395	140	140	500	500	5	9	3000	3500	
	2W350	3500	2310	4205	4595	140	140	500	500	5	9	3000	3500	
	2W360	3600	2360	4305	4695	140	140	500	500	5	9	3000	3500	
	2W400	4000	2610	4705	5095	140	140	500	500	5	9	2850	3250	
	2W430	4300	2760	5005	5395	140	140	500	500	5	6	2700	3000	
2W450	4500	2860	5205	5595	140	140	500	500	5	6	2550	2850		
Duplex ZZ	2F250	2500	1790	3215	3595	1075	695	500	500	5	9	3000	3500	
	2F270	2700	1890	3415	3795	1175	795	500	500	5	9	3000	3500	
	2F300	3000	2040	3715	4095	1325	945	500	500	5	9	3000	3500	
	2F330	3300	2190	4015	4395	1475	1095	500	500	5	9	3000	3500	
	2F360	3600	2340	4315	4695	1625	1245	500	500	5	9	3000	3000	
	2F400	4000	2440	4715	5095	1725	1345	500	500	5	9	2850	3000	
Triplex DZ	3F430	4300	2040	5005	5395	1335	945	515	515	5	6	2550	3250	
	3F450	4500	2120	5205	5595	1415	1025	515	515	5	6	2400	2850	
	3F480	4800	2225	5505	5895	1520	1130	515	515	5	6	2250	2500	
	3F500	5000	2310	5705	6095	1605	1215	515	515	5	6	2100	2300	
	3F550	5500	2560	6205	6595	1855	1465	515	515	3	6	1650	1750	
	3F600	6000	2810	6705	7095	2105	1715	515	515	3	6	1200	1250	

## Relevante Traglasten mit Lastschwerpunkt Grafik

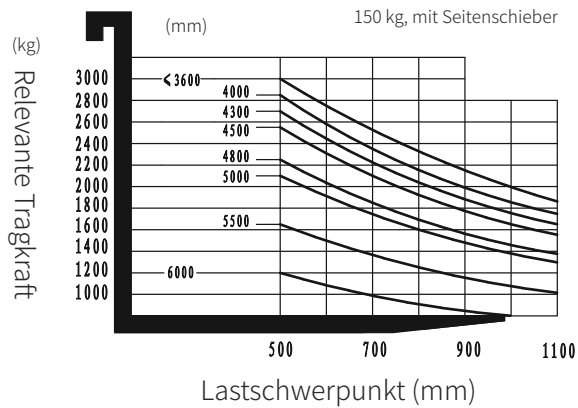

## Relevante Traglasten mit Lastschwerpunkt Grafik

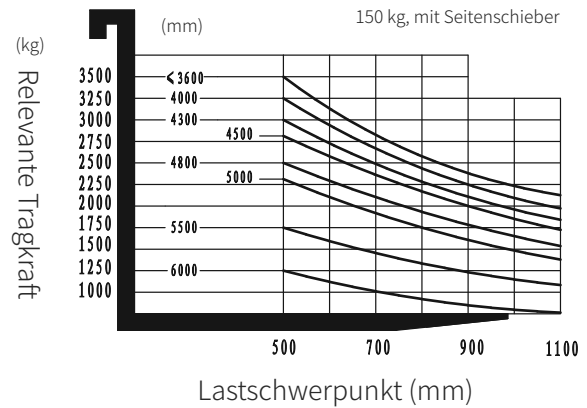

## Optionen

No.	Optionale Elemente	CPD30L1S	CPD35L1S
1.1	Gabellänge	<ul style="list-style-type: none"> <li>○ 122*45*1070 ○ 122*45*1150 ○ 122*45*1220</li> <li>○ 122*45*1370 ○ 122*45*1520 ○ 122*45*1600</li> <li>○ 122*45*1700 ○ 122*45*1820 ○ 122*45*2000</li> <li>○ 122*45*2200 ○ 122*45*2400</li> </ul>	<ul style="list-style-type: none"> <li>○ 122*50*1070 ○ 122*50*1150 ○ 122*50*1220</li> <li>○ 122*50*1370 ○ 122*50*1520 ○ 122*50*1600</li> <li>○ 122*50*1700 ○ 122*50*1820 ○ 122*50*2000</li> <li>○ 122*50*2200 ○ 122*50*2420</li> </ul>
1.4	Breite des Gabelträgers	● 1100mm ○ Yes and can be customized	● 1100mm ○ Yes and can be customized
1.5	Höhe der Rückenlehne	● 1094mm ○ Yes and can be customized	● 1094mm ○ Yes and can be customized
2.5	Material Vorderrad	● Solid ○ Non-marking solid	● Solid ○ Non-marking solid
2.6	Material Hinterrad	● Solid ○ Non-marking solid	● Solid ○ Non-marking solid
2.7	Batteriekapazität	● 80V560AH	● 80V560AH
2.8	Ladegerät	○ 80V130A ○ 80V200A	○ 80V130A ○ 80V200A
2.9	Batterieanzeige	● With time	● With time
2.10	Fahrersitz	<ul style="list-style-type: none"> <li>● Premium ○ Suspension ○ Suspension+Seatbelt logic switch</li> <li>○ Suspension seat with armrest (KL01)</li> </ul>	<ul style="list-style-type: none"> <li>● Premium ○ Suspension ○ Suspension+Seatbelt logic switch</li> <li>○ Suspension seat with armrest (KL01)</li> </ul>
2.11	Anbaugeräte	<ul style="list-style-type: none"> <li>● No ○ Built-in sideshifter</li> <li>○ External shifter ○ Fork positioner</li> </ul>	<ul style="list-style-type: none"> <li>● No ○ Built-in sideshifter</li> <li>○ External shifter ○ Fork positioner</li> </ul>
2.13	Traktionsbolzen	● Yes	● Yes
2.14	antistatische Kette	● No ○ Yes and not customized	● No ○ Yes and not customized
3.5	Scheinwerfer vorn	● LED	● LED
3.6	Scheinwerfer hinten	● No ○ LED	● No ○ LED
3.7	Warnlicht	● Yes	● Yes
3.8	Lenkradlampe	● Yes	● Yes
3.9	Blaue Signalleuchte	● No ○ 2 front ○ 1 rear ○ 2 front + 1 rear	● No ○ 2 front ○ 1 rear ○ 2 front + 1 rear
3.10	Bereichs-Warnleuchte	● No ○ Red, 1 left + 1 right	● No ○ Red, 1 left + 1 right
3.11	Rückspiegel	● 1 rearview mirror ○ Add one on both sides	● 1 rearview mirror ○ Add one on both sides
3.12	Hupe	● Yes	● Yes
3.15	Feuerlöscher	● No ○ Yes and not customized	● No ○ Yes and not customized
3.17	OPS system	● No ○ Yes and not customized	● No ○ Yes and not customized
3.19	USB-Schnittstelle	● Yes	● Yes
3.23	Telematics	● No ○ Yes and not customized	● No ○ Yes and not customized
4.3	Kabine	<ul style="list-style-type: none"> <li>● No ○ Basic semi-enclosed cabin</li> <li>○ Upgrade semi-enclosed cabin ○ Full cabin</li> </ul>	<ul style="list-style-type: none"> <li>● No ○ Basic semi-enclosed cabin</li> <li>○ Upgrade semi-enclosed cabin ○ Full cabin</li> </ul>
4.5	Proportionalventil	● Yes	● Yes
4.9	Heizgerät	● No ○ Yes and can be customized	● No ○ Yes and can be customized

Note: ● Standard ○ Optional - Inconformity